



SMART GUARD ULTRA ZERO AIR LOSS DRAIN



Programmable!



The Smart Guard Ultra was designed to remove condensate from compressed air systems up to 3600 SCFM (compressor capacity).

The Smart Guard Ultra offers true programming flexibility. The software incorporates alarm options and anti-air-lock options which may be activated according to your requirements. Effectively, one unit truly does it all.

The operation is automatic and there is zero air loss during the condensate discharge cycle.

Technical Advantages

- » Large (4.5mm) valve orifice
- » Condensate inlet height only 3.35"
- » The valve is fully serviceable
- » Integrated mesh strainer
- » TEST Feature

Commercial Benefits

- » Zero air loss during the condensate discharge cycle
- » Compressed air system up to 3600 SCFM (compressor capacity)
- » Simple and easy maintenance procedure
- » Alarm and anti air-lock programming features incorporated
- » SMS Text Service available



SMART GUARD ULTRA ZERO AIR LOSS DRAIN

Product Dimensions:

25.4mm = 1"

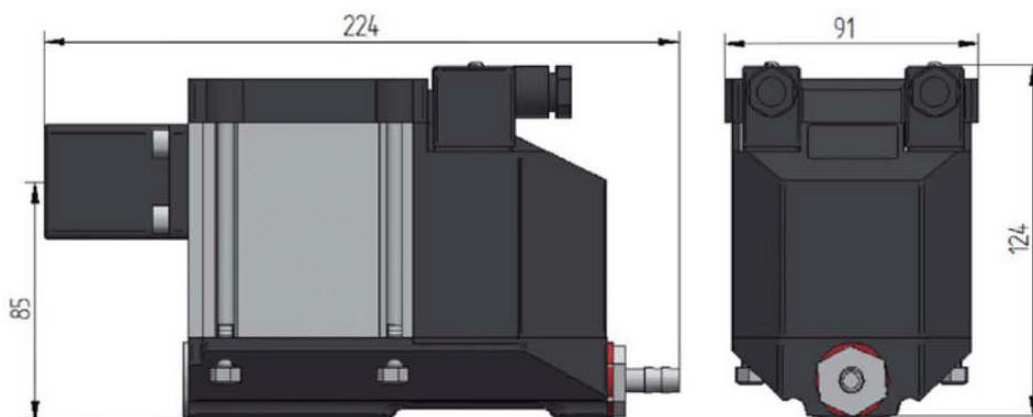

Features

Maximum compressor capacity	3600 SCFM
Inlet/outlet connection	1/2" NPT
Inlet height	3.35"
Valve orifice	4.5 mm
Minimum/maximum system pressure	0 PSI / 230 PSI
Minimum medium temperature	34° F
Maximum medium temperature	150° F
Serviceable Valve	yes
Valve seals Viton	(FPM)
Environmental protection	IP65/Nema 4
Alarm option (A1 & A2)	yes, incorporated as standard
Anti-air-lock/BIO option	yes, incorporated as standard
Service interval warning system	yes, incorporated as standard